

General

Alpha Panel Minipleat HEPA/ULPA filters are available in two particle size efficiencies: 99.99% on 0.3 μm and 99.99% on 0.12 μm . They are offered in a complete range of standard sizes to meet the needs of critical applications where HEPA/ULPA filtration is required. Individual testing under rigid quality control and modern assembly methods ensures conformance to specifications.

Construction

Filter media is manufactured of moisture resistant microfine fiberglass that is formed into closely-spaced pleats held firmly in place with polyurethane sealant bead separators. The 2.1" (53 mm) separatorless minipleat panel is urethane sealed into a clearcoat-anodized extruded aluminum frame. Media dividers are furnished on all filters over 36" width. Filters over 24" height are also furnished with media dividers and in pleats that are parallel to the width.

Alpha Panel HEPA/ULPA filters can be furnished with 0.25" thick x 0.75" wide closed cell neoprene gaskets as an option on either side or both sides of the face flanges.

Testing

Each Alpha Panel HEPA/ULPA filter is scan tested after assembly with automated laser equipment to ensure that it has attained a particle size efficiency of at least 99.99% on 0.30 μm or 99.99% on 0.12 μm . This performance meets the requirements of the Institute of Environmental Sciences and Technology (IEST) RP-1 for Type C or F filters. Efficiency and pressure drop are certified on each filter identification label.

Installation

Alpha Panel HEPA/ULPA filters are used in applications and equipment that require ultraclean air. These may range from the fabrication of microelectronics, semi-conductors and medical devices to aerospace, biotech and pharmaceutical manufacturing.

The standard face velocity range of 70 to 110 fpm makes them ideal for unidirectional (laminar flow)

applications in clean benches, ceiling grids, fan powered filter units, and horizontal flow wall modules.

Filters of standard construction may be operated at up to 150 fpm face velocity and to a final static pressure drop of 2.0 inch w. g. As with all HEPA and ULPA filters, high efficiency ASHRAE-rated pre-filters are recommended.

Physical Data

Media: Moisture-resistant microfine fiberglass

Filter pack: 2.1" (53 mm) separatorless minipleat

Media sealant: Urethane

Pleat stabilizers: Polyurethane bead separator

Frames: Clearcoat-anodized extruded aluminum

Media dividers: Extruded aluminum channel

Gaskets: Closed cell neoprene

Important Features

- Minipleat separatorless filter pack
- Thin and lightweight easy-to-handle units
- Rugged 3" deep clearcoat-anodized extruded aluminum frame
- Available in many standard sizes



Performance Data - Capacities and Dimensions

Particle Size Efficiency	Model Number	Actual Dimensions (inch)		Cfm Capacity at Gross Face Velocity, fpm		
		H	W	70	90	110
99.99% on 0.30 Fm	AP493-2424*	24	24	280	360	440
	AP493-2448*	24	48	560	720	880
	Clean Filter Resistance (inch w.g.)				.35	.45
99.99% on 0.12 Fm	AP591-2424*	24	24	280	360	440
	AP591-2448*	24	48	560	720	880
	Clean Filter Resistance (inch w.g.)				.50	.65

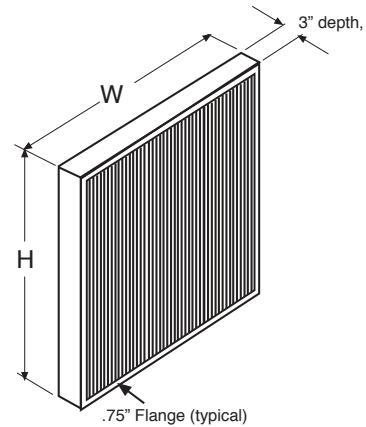

*Insert gasket designator: D, U, B or N. See Note 5.

Drawing Notes:

- Physical Data
 - Media: Moisture-resistant fiberglass
 - Filter Construction: 2.1" (53 mm) thick separatorless minipleat
 - Filter Frame: Clearcoat-anodized extruded aluminum
 - Media Divider: Extruded aluminum channel
- Add 0.25" to the 3" depth for each gasket.
- Media dividers are furnished on air filters over 36" in width. Filters over 24" in height are also furnished with media dividers and media pleats that are parallel to the width.

Performance Data Notes:

- Filters are scan-tested for leaks after assembly and are certified to be 99.99% on 0.30 Fm or 99.99% on .012 Fm particles. Performance meets the requirements of IEST RP-1 for Type C or F filters.
- Dimensional tolerances are +0" -.13" on height and width, + 0.6" on depth and +.13" on diagonal dimensions.
- Maximum operating conditions: 200 degrees F, 100% RH.
- Filters are designed to UL 900 Class 2 requirements.
- Gasket location: Suffix D denotes a downstream gasket. Use suffix U for upstream, B for both upstream and downstream gasketing and N if no gaskets are required.

Guide Specifications

1.0 General

- Minipleat HEPA/ULPA filters shall be Alpha Panel Model AP493 or AP591 as manufactured by Flanders.
- Filter sizes and capacities shall be as scheduled on the drawings.
- Filter construction shall meet UL 900 Class 2 requirements.

2.0 Construction

- The filter pack shall be 2.1" (53 mm) thick and shall consist of moisture-resistant microfibre fiberglass containing a water-repellant binder. The media shall be formed into closely spaced pleats and stabilized with polyurethane bead separators.
- The filter pack shall be urethane sealed in a clearcoat-anodized extruded aluminum frame

3" deep.

- Extruded aluminum media dividers shall be provided on filters over 36" wide and 24" in height.
- Furnish 0.25" thick x 0.75" wide closed cell neoprene gaskets on the face flanges when required.

3.0 Performance

- Particle size efficiency shall be certified to be not less than 99.99% on 0.30 micron or 99.99% on 0.12 micron. Each filter is scan tested with automated laser equipment. Filters shall meet the requirements of IEST RP-1 for Type C or F filters.
- Initial resistance shall not exceed the scheduled values.
- Filters shall be capable of operating up to 150 fpm face velocity.

REPRESENTED BY:

Flanders Precisionaire
Foremost in Air Filtration
Engineered Products: 1-800-637-2803
Replacement Products: 1-800-347-2220

