

## General

Flanders Alpha 95 Filters are designed for use in HVAC applications requiring cleaner air than is possible with ASHRAE rated filters, but where HEPA filtered air is not required. The filters are rated at 95% efficiency on 0.30 micrometer particles by the DOP test method. The Alpha 95 filter is approximately 99% efficient by the ASHRAE 52.1 dust spot test methods. However, it is not rated by these methods because the standard applies to filters no greater than 98% efficient.

Alpha 95 Filters are identical in design and construction to the Alpha Cell HEPA Filters except that the media is 95% efficient on 0.30 micrometer particles.

## Installation Considerations

Alpha 95 Filters should be installed in Flanders leak tight Alpha HEPA frames or Surelock Side Access HEPA Housings on the positive-pressure side of the system fan to prevent air bypass. Sureaire diffuser sections, air mixing baffles or long transitions should be used if the bank is close to the fan.

Installation of Flanders 80-85% ASHRAE efficien-

cy prefilters upstream of the fan is recommended to ensure economical Alpha 95 Filter life.

Standard Alpha 95 Filters have 1.7 times the cfm capacity of standard Alpha Cell 99.97% DOP HEPA Filters at the same clean pressure drop. They are normally rated at 500 fpm so that filter banks with 95% DOP filters can be sized the same as ASHRAE-rated filter banks.

## Typical applications for Alpha 95 include:

- Hospitals
- Biomedical
- Pharmaceutical
- Biotechnology
- Genetic Research
- Universities
- Laboratories
- Food Processing
- Photo Processing
- Semiconductor Fabrication
- Industrial Processing Systems Product

## Important Features

- Minimum efficiency is 95% on 0.30 micrometer particles.
- Manufactured in a variety of wood and metal frame types.
- Available with a media pack with aluminum separators or with a separatorless pack.
- Available in a variety of sizes with either a gasket seal or gel seal.



Alpha 95 Filter Dimensions and Capacities						
Filter Depth (inches)	Filter Size and Frame Depth Designator	Actual Face Size (Inches)	CFM Capacity at Clean Pressure Drop, Inches w.g.			Weight (lbs)
			.70	1.0	1.33	
11-1/2	GG-F	24x24	1375	2000	2560	38
	GC-F	24x12	650	920	1180	26
	YY-F	23-3/8x23-3/8	1350	1900	2450	37
	YUF	23-3/8x11-3/8	610	865	1150	25
	GN-F	24x30	1750	2550	3250	45
	CC-F	12x12	290	430	550	14

## Construction

Flanders manufactures both conventional Separator Style and Pureform Separatorless 95 DOP Filters. To make a Separator Style filter, the media is folded over corrugated aluminum separators with hemmed edges to separate the pleats in the filter pack. Flanders manufactures its own filter media, enabling it to develop a unique manufacturing process for the production of Pureform Separatorless 95 DOP Filters. In one manufacturing operation, Flanders produces a self-supporting and self-separating Pureform Media Pack.

The Pureform Filter offers many advantages over conventional Separator Style 95% DOP Filters:

- Increased usable media area affords longer service life and higher dust holding capacity
- Maximum utilization of the media
- Can handle some harsh environments which may attack aluminum separators
- Media pack can be incinerated
- Media is 28 mils, significantly thicker than conventional media used in Separator Style 95 DOP Filters (15 mil)
- Pureform has 25% more media area than conventional style.
- Ideal for heavy loading applications such as oil mist or tobacco smoke

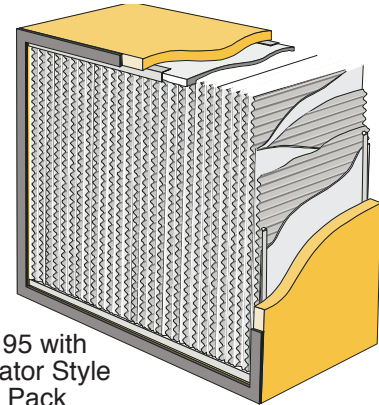

Alpha 95 with Separator Style Media Pack

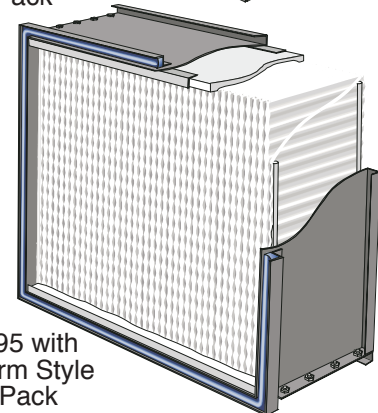

Alpha 95 with Pureform Style Media Pack

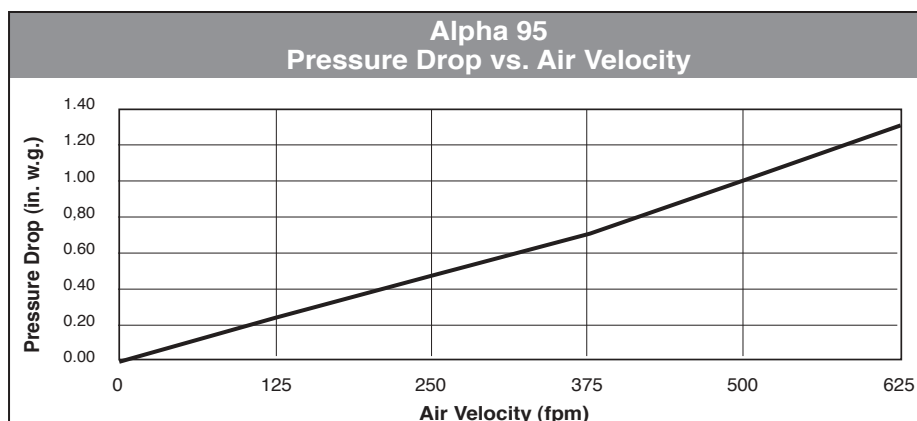

**Flanders Precisionaire - Foremost in Air Filtration**

**Engineered Products: 1-800-637-2803    Replacement Products: 1-800-347-2220**

# ALPHA 95 COMPONENT CHART

0 - 00J - W - 08 - 03 - IU - 12 - 00 - GG - F

## Hardware

0 = None  
T = Extractor Clips

## Efficiency

00J = 95% DOP

## Capacity/Pack Style

C = Separator  
D = 4 inch Pureform  
F = 8 inch Pureform  
W = 11 inch Pureform

## Frame Material

02 = 16 GA 409 Stainless  
03 = 16 GA 304 Stainless  
04 = 3/4 in. FIRE RETARDANT PLYWOOD  
05 = FABRICATED ALUMINUM  
07 = 3/4 in. FIRE RETARDANT PARTICLE BOARD  
08 = 16 GA. GALVANNEAL  
11 = 3/4 in. NON FIRE RETARDANT PARTICLE BOARD  
17 = CORROSION-RESISTANT 24 GA. STEEL

## Frame Style

00 = BOX  
01 = SINGLE HEADER (13/16")  
02 = DOUBLE HEADER (13/16")  
03 = DOUBLE TURNED FLANGE  
05 = 3/4 IN. DEEP CHANNEL  
08 = DOUBLE-TURNED FLANGE, ONE SIDE

## Sealant Material

IU = URETHANE  
IH = HOT MELT PACK

## Gasket material

0 = NONE  
1 = NEOPRENE  
5 = BLUE JEL

## Gasket location

0 = NONE  
1 = UPSTREAM  
2 = DOWNSTREAM  
3 = BOTH SIDES

## Filter Depth

D = 5-7/8"  
F = 11-1/2"

## Filter Face Size (HxW)

B = 8"	N = 30"	R = 6
C = 12"	P = 36"	S = 72"
E = 18"	H = 42"	U = 11-3/8"
G = 24"	Q = 48"	Y = 23-3/8"

## Odd Size Designator

Odd size designators are an Alpha Numeric description. The first two digits specify the height whole number with an alpha designator specifying the height fraction. The second two digits specify the width whole number with an alpha designator specifying the width fraction. And the last alpha designator specifies the depth. If the height or width is less than 10 inches, use a 0 in front of the dimension.

A = 0"	F = 5/16"	L = 5/8"
B = 1-1/16"	G = 3/8"	M = 11/16"
C = 1/8"	H = 7/16"	N = 3/4"
D = 3/16"	J = 1/2"	P = 13/16"
E = 1/4"	K = 9/16"	Q = 7/8"
		R = 15/16"

## Faceguard Material

0 = NONE  
1 = GALVANIZED 4X4 MESH  
G = ALUMINIZED EXPANDED METAL  
2 = 17GA. SS 4X4 MESH  
5 = 22 GA. SS 4X4 MESH

## Faceguard Location

0 = NONE  
1 = UPSTREAM  
2 = DOWNSTREAM

**Frame:** Alpha 95 Filters are available in a variety of wood and metal frame materials such as particle board, plywood, galvanized steel and stainless steel. Alpha 95 filters are also available in 24 gauge corrosion resistant steel in single or double headers for installation in side access or plenum applications.

**Seal:** The standard gasket seal is 0.75" x 0.25" neoprene for installation on either the upstream, downstream or both sides of the filter. The standard Fluid Seal is Flanders Blu-Jel® Seal which is a two - part silicone material suitable for temperatures up to 390°F.

**Faceguards:** Faceguards are used to protect the filter media from mechanical damage. The typical faceguard material is expanded aluminized steel. Galvanized 4 x 4 mesh welded wire and Type 304 stainless steel faceguards are also available.

**UL:** Alpha 95 Filters are either UL900 Class 1 or Class 2 listed depending on materials of construction.

**Banks:** Alpha Frames are designed for Alpha 95 filters in built-up filter banks. Each filter is secured in the frame with four bolt-type fasteners that either compress the gasket or press the knife edge into the gel in the filter channel to maintain a leak-tight seal. Surelock HEPA Filter Housings are recommended for side-access applications. The filters are sealed in place with either spring-loaded swing arm assemblies or a locking mechanism. The swing arm assemblies or locking mechanism either compress the gasket or press the knife edge into the gel in the filter channel to maintain a leak-tight seal.

Flanders Precisionaire - Foremost in Air Filtration

Engineered Products: 1-800-637-2803 Replacement Products: 1-800-347-2220

## Guide Specifications

### 1.0 General

- 1.1 Alpha 95 filters shall be extended media (separator type) (Pureform separatorless type) filters as manufactured by Flanders.
- 1.2 Filter sizes, capacities and construction options shall be as scheduled on the drawings.
- 1.3 Filters shall be (UL 900 Class 1)( UL 900 Class 2) listed.

### 2.0 Filter Construction

- 2.1 The filter pack shall be constructed by pleating a continuous sheet of non-woven water-resistant fiberglass media around hemmed-edge corrugated aluminum separators. The filter pack shall be constructed by pleating a continuous sheet of formed, corrugated medium so that the pack is self-supporting without the use of spacers of any kind, including separators, tape strings, adhesives or strips of media.

2.2 The filter pack shall be sealed into a (galvaneal) (409 stainless steel) (304 stainless steel) (particleboard) (fire retardant particleboard) (fire retardant plywood) frame with a fire retardant (polyurethane foam) (solid urethane) sealant. (Steel frames shall be 16 ga.) (Wood frames shall be 3/4" thick.)

2.3(A 40-durometer closed-cell neoprene gasket) (Silicone gel in a channel) shall be provided on one or more sides to seal the filter in the mounting device.

### 3.0 Performance

- 3.1 Initial and final resistances shall not exceed the scheduled values.
- 3.2 The rated minimum efficiency of 95% on 0.3 micrometer size particles shall be as determined by the DOP Test Method

**Flanders Precisionaire**  
**Foremost in Air Filtration**  
**Engineered Products: 1-800-637-2803**  
**Replacement Products: 1-800-347-2220**

REPRESENTED BY:

