

pharmaseal® ducted ceiling module

Roomside Replaceable Ducted Ceiling Module



The only fully-welded
HEPA filter terminal
housing.



The Pharmaseal is available with a bubble-tight damper¹, a guillotine damper or a butterfly damper.

¹ Patent pending.

The Camfil Farr Pharmaseal provides cleanroom level air filtration for pharmaceutical or biotechnology facilities as well as any other facility where clean space is a manufacturing or health-related requirement. Its unique roomside replaceable filter design minimizes downtime and ensures repeatable room air cleanliness following filter service. The Camfil Farr Pharmaseal:

- Has joints and penetrations in the filter-to-module interface that are of welded component construction. Leaks into the cleanroom are eliminated.
- Housing is leak tested at 3.0" w.g. to ensure the housing will not leak under normal operating conditions. The housing is also visually inspected and tested for filter fit.
- Is manufactured in various configurations from 0.063 aluminum or 16-gauge stainless steel.
- May be installed in a T-bar ceiling or flush mounted in a solid ceiling.
- May be ordered with a bubble-tight, guillotine, or butterfly style damper.
- The bubble-tight and volume control damper allow for 100% shut-off for decontamination and volume control from the same control mechanism within the housing.
- Includes an aerosol distribution system for uniform dispersion across the entire face of the filter.
- Includes a raised-rib inlet collar for easy connection to a flexible HVAC or air duct supply.
- Includes a flush-mounted face grille for unit service. The grille is optimized to promote uniform airflow and is available with a full-edge hinge.
- Accepts gel seal filters that are available in efficiencies from 99.99% at 0.3 micron to 99.9995% at most penetrating particle size.

Camfil Farr's flexible fabrication capabilities can supply a Pharmaseal for virtually any cleanroom requirement. Designed with the pharmaceutical industry in mind, the Pharmaseal may also be applied in medical, food processing, photographic and microelectronics facilities or any process where ultra clean air is a requirement.



Camfil Farr	Product sheet
Pharmaseal®	3420 - 0207
Camfil Farr - clean air solutions	

2 Quick-Access Removable Hinged Grille

The grille may be completely removed during service through the use of a unique removable hinge grille assembly. Constructed of stainless steel, the grille ensures protection of the filter and internal housing components and has a 40% open area.

External Insulation (not shown)

Pharmaseal modules are available with either external foil-back insulation or closed-cell elastomeric insulation. Unit may be insulated on the top, sides, or both.

3 Fasteners

Grille fasteners are available with acorn nuts or quarter-turn fasteners.



Acorn Nut



¼-turn Fastener

4 Static Pressure Port

A static pressure port for measuring the pressure drop across the installed filter is standard. The port is also available with a quick-disconnect fitting.



200 Creekside Dr.
Washington, NC 27889
Phone: 252-9751141
Fax: 252-9751041

Pharmaseal Hood

MODEL NO: PH25D25D12DDG10RTSAC2C1A2
PART NO: M80000016
FILTER SIZE: 21-3/4" x 18-3/4"
MAX. FILTER PACK DEPTH: 100 mm
CAMFIL FARR ORDER NO: 658682

S/N: 6 5 8 6 8 2 - 0 0 3 0

(MADE IN THE USA)

Full Product Detail on Unit Labels

Serial numbers are assigned to each hood after leak testing. This allows testing traceability.

1 Removable or Permanent Trim

Stainless steel roomside trim is available. The trim may be removable or permanent as required.

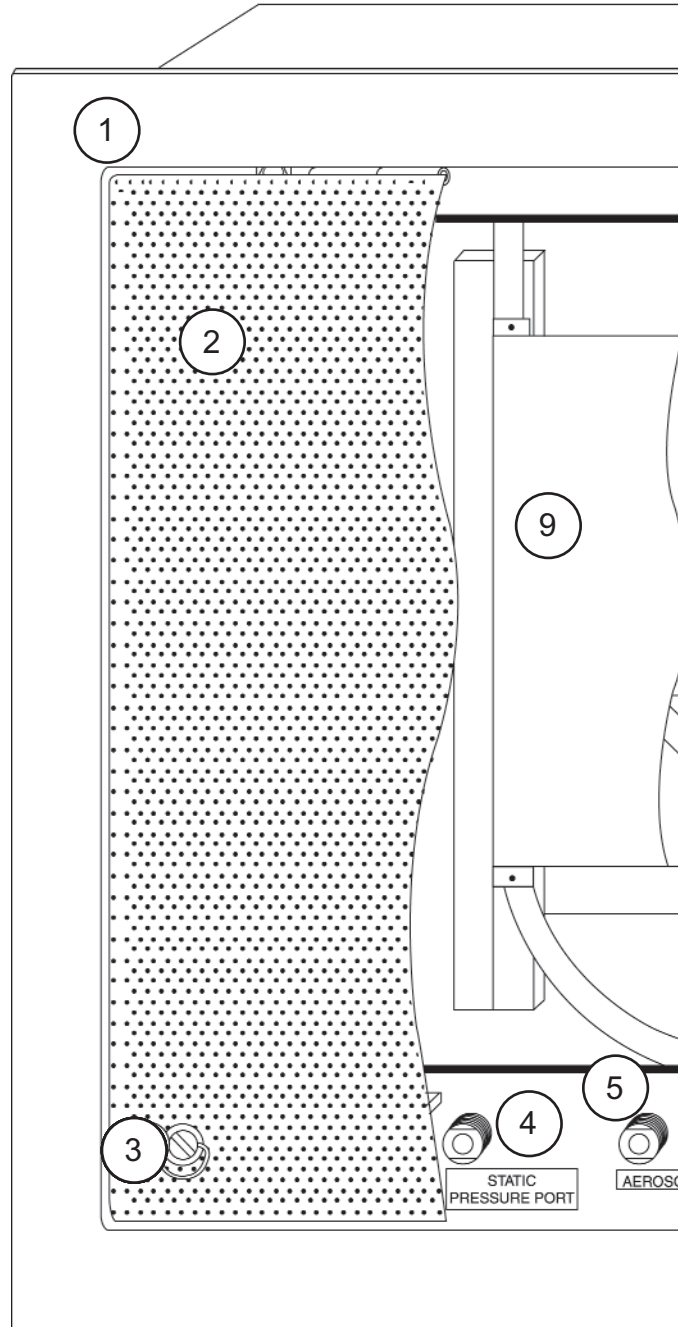

5 Aerosol Injection Port



The standard aerosol injection port is sealed with a plug (included). A quick-disconnect aerosol injection port is also available (shown to left).

13 Gel-Penetrating Knife Edge

The Camfil Farr PharmaSeal includes a gel-penetrating knife-edge that affects a positive seal.

12 Hanging Support Tabs

The PharmaSeal is available with hanging tabs or mounting pads for connection to an external support system.



11 Guillotine Damper Mechanism

Heavy-duty linkage for guillotine dampers.

10 Damper Options

The Camfil Farr Pharmaseal incorporates a guillotine damper as standard. Airflow can be regulated between 10% and 98%. A bubble-tight damper, butterfly damper, or stand-alone air diffuser plate is also available.

9 Solid Air/Aerosol Diffuser Plate

The air/aerosol diffuser plate ensures adequate dispersion of filter challenge for filter testing and/or room certification. The challenge is spread evenly across the face of the filter so that filters can be scan tested. It also ensures uniformity of airflow through the filter.

7 Filter Guides

Filter guides assist in centering and ensure proper filter placement during filter service. Filter guides are standard on all PharmaSeal hoods.

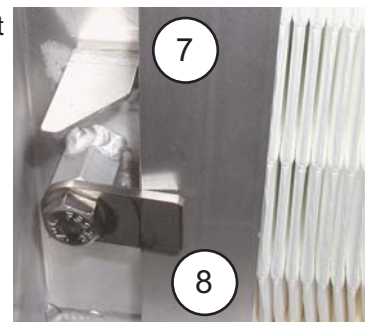

8 Filter Retention Tabs

Filter retention tabs secure the filter on the gel track and within the assembly.

6 External Damper Adjustment

In the service area of the housing, a damper position adjustment mechanism allows airflow regulation from the room side of the hood. The bubble-tight and guillotine dampers have position indicators to assist with room re-balancing.

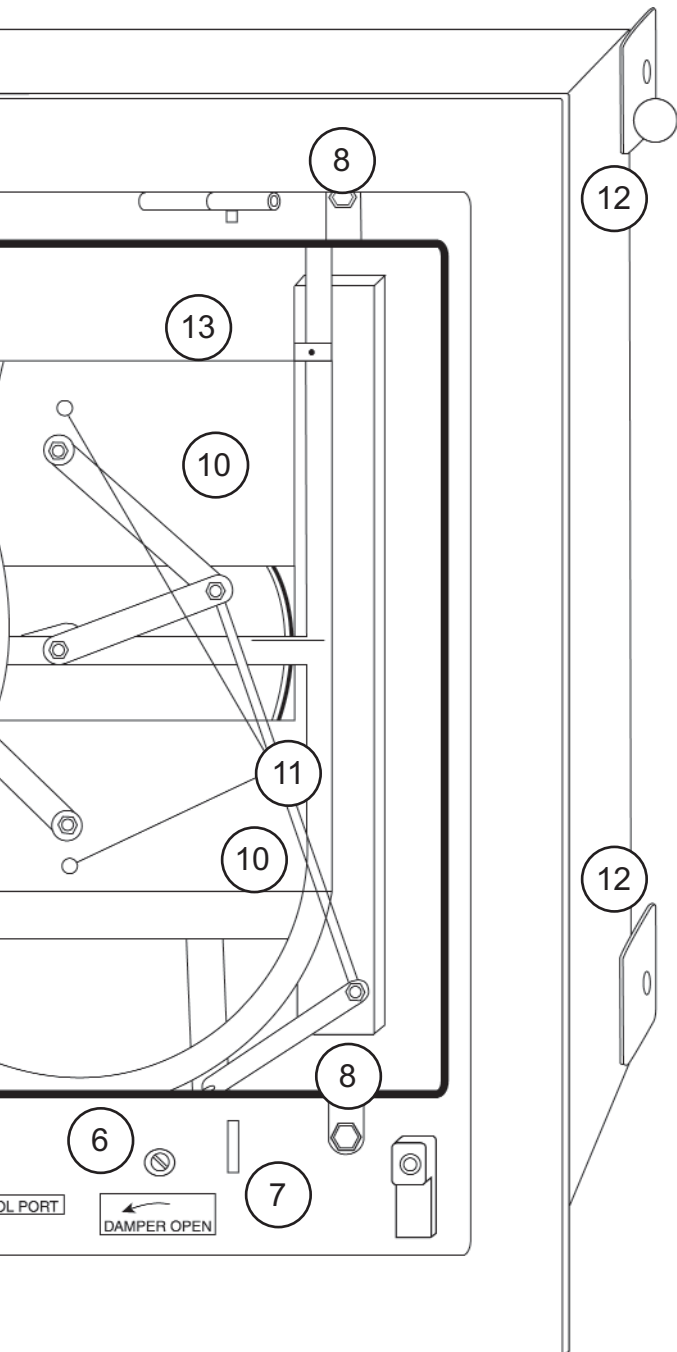

Inside the Bubble-Tight Pharmaseal Housing

Volume control and a bubble-tight damper (guaranteed to 4" w.g.)¹ in a terminal (or exhaust) housing is now available from the same room side control mechanism from within the housing for the first time!

Fine Damper Adjustment Control - Damper adjustment is 13 revolutions from fully open to fully closed. This allows for fine tuning the airflow through the system.

Aerosol Injection Ring – Integrated aerosol injection ring and distribution plate for in-place testing.

Proven Design - Damper has fluid seal channel that mates with a knife edge in the hood. This is the same technology that has been used for years to seal HEPA and UHPA filters in hoods.

High Cycle Life - Positive stops on the damper adjustment mechanism eliminate twisting of the stainless steel flexible cable, providing high-cycle life. Cable failure is greatly reduced.

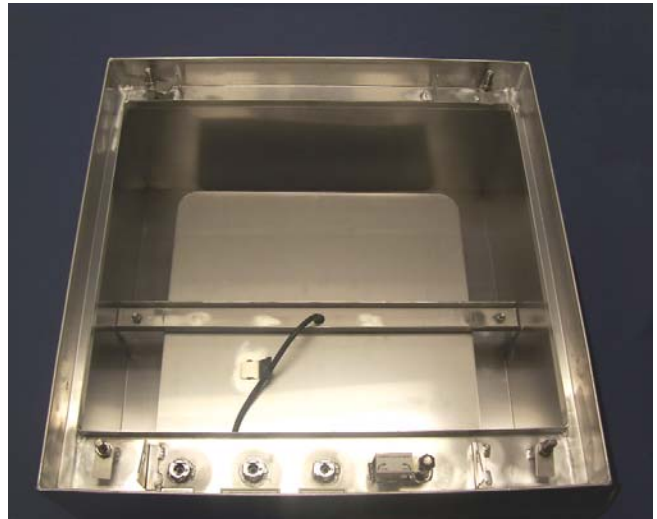

Bubble-tight Damper (Patent pending)

- Enables complete isolation of Pharmaseal allowing for changeout of filters without risk of contamination to the cleanroom
- May eliminate the need for full room decontamination during filter replacement depending on the application
- Designed to reduce production downtime during filter change-out and room decontamination

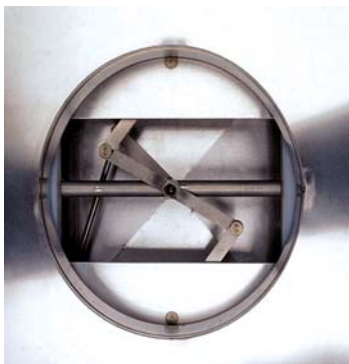

Guillotine Damper

- Room balancing and airflow control are easily adjusted using the ¼-turn rotary mechanism attached to a robust mechanical linkage and heavy-duty blades
- Damper assembly is welded to hood body to increase rigidity and eliminates “binding” of damper blades common in pop-riveted units
- Damper position indicator included



Butterfly Damper

- Heavy-duty damper mechanism features threaded shaft and driven nut, eliminating “slipping” and “binding” which are common with worm-screw and gears
- Cost-effective damper for localized fine-tuning of airflow through the housing



Bubble-tight & Guillotine damper Pharmaseals include a fully welded inlet collar.

¹ Certificates of Compliance may be provided upon customer request.

Trim Options (others are available, please contact factory for assistance)(drawings not to scale):

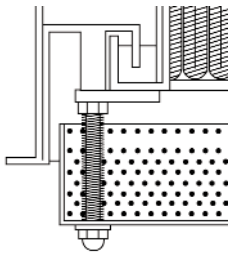

Extended grille/permanent trim
2" extended stainless steel grille with acorn nuts and 5/8" permanent trim.

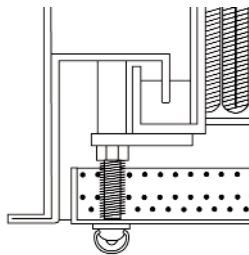

Flush grille/permanent trim
Flush stainless steel grille with 1/4-turn fasteners on a hinged grille with 5/8" permanent trim.

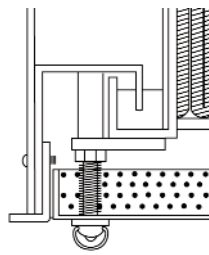

Flush grille/permanent trim
Flush stainless steel grille with 1/4-turn fasteners on a hinged grille with 5/8" permanent SST trim on an aluminum hood body.

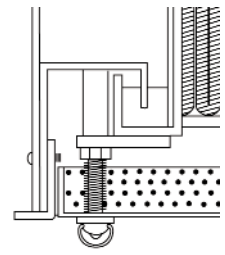

Flush grille/removable trim
Flush stainless steel grille with 1/4-turn fasteners on a hinged grille with 1-1/2" removable SST trim on an aluminum hood body.

Camfil Farr Pharmaseal[®] Filters

(ordered separately)

Camfil Farr Pharmaseal Filters provide fine particulate control to meet the requirements of today's high technology cleanrooms and clean areas. Offering configuration and performance flexibility, the Pharmaseal filter will provide the highest level of protection for product processes and personnel. *Standard Gel seal filters contain polyurethane gel for knife edge seal. Silicone gel is recommended when a high degree of cleaning and sterilization agents are used or in a high temperature application.* Each Camfil Farr Pharmaseal filter includes:

- Micro glass fiber media in efficiencies of 99.99% @ 0.3 micron to 99.9995% at most penetrating particle size (MPPS). The media is pleated using Camfil Farr's Controlled Media Spacing™ technology. CMS™ ensures optimized filter element depth and pleat spacing, resulting in minimized configuration losses and low resistance to airflow.
- Continuous glass filament or thermoplastic separators to ensure uniform pleat spacing and form a rigid self supported media pack. Media-to-media contact, and associated fiber break-off, are eliminated.
- A heavy-duty, lightweight anodized aluminum frame for high strength and ease of installation. The frame corners are secured with Camfil Farr's exclusive Klip-Lok™ mechanism for module durability and long-term integrity.
- A media pack is sealed on all four sides using Camfil Farr's CamPure™ polyurethane sealant. CamPure is a fire-retardant, thermally/chemically stable, shock-adsorbing polyurethane elastomer sealant assuring leak-free integrity and low-out gassing.
- Is manufactured in an ISO Class 7 (M 5.5, Class 10,000) cleanroom and tested in an ISO Class 5 (M 3.5, Class 100) clean space.
- Is tested using Camfil Farr's AUTO-SCAN™ automated leak detection system. *Filters are serialized, bar coded, and all data is provided on a label on the filter. This allows for filter traceability back to the raw goods of unit construction.*

Pharmaseal Filters	Actual Size		Rate Airflow (cfm)	Initial Resistance (inches w.g.)
	Width	Length		
53 MM HEPA (99.99% @ 0.3 micron)				
QX-21.75-18.75-5-41-VU-00-00-0	21 3/4	18-3/4	217	0.52
QX-21.75-20.00-5-41-VU-00-00-0		20	233	
QX-21.75-42.75-5-41-VU-00-00-0		42-3/4	538	
QX-21.75-44.00-5-41-VU-00-00-0		44	554	
53 MM H14 (99.995% @ MPPS)				
HX-21.75-18.75-5-41-VU-00-00-0	21 3/4	18-3/4	217	0.52
HX-21.75-20.00-5-41-VU-00-00-0		20	233	
HX-21.75-42.75-5-41-VU-00-00-0		42-3/4	538	
HX-21.75-44.00-5-41-VU-00-00-0		44	554	
53 MM ULPA (99.9995% @ MPPS)				
P7-21.75-18.75-5-41-VU-00-00-0	21 3/4	18-3/4	217	0.68
P7-21.75-20.00-5-41-VU-00-00-0		20	233	
P7-21.75-42.75-5-41-VU-00-00-0		42-3/4	538	
P7-21.75-44.00-5-41-VU-00-00-0		44	554	
70 mm HEPA (99.99% @ 0.3 micron)				
QX-21.75-18.75-7-40-VU-00-00-0	21 3/4	18-3/4	217	0.44
QX-21.75-20.00-7-40-VU-00-00-0		20	233	
QX-21.75-42.75-7-40-VU-00-00-0		42-3/4	538	
QX-21.75-44.00-7-40-VU-00-00-0		44	554	
70 mm H14 (99.995% @ MPPS)				
HX-21.75-18.75-7-40-VU-00-00-0	21 3/4	18-3/4	217	0.44
HX-21.75-20.00-7-40-VU-00-00-0		20	233	
HX-21.75-42.75-7-40-VU-00-00-0		42-3/4	538	
HX-21.75-44.00-7-40-VU-00-00-0		44	554	
70 mm ULPA (99.9995% @ MPPS)				
PX-21.75-18.75-8-40-VU-00-00-0	21 3/4	18-3/4	217	0.48
PX-21.75-20.00-8-40-VU-00-00-0		20	233	
PX-21.75-42.75-8-40-VU-00-00-0		42-3/4	538	
PX-21.75-44.00-8-40-VU-00-00-0		44	554	
100 mm HEPA (99.99% @ 0.3 micron)				
QX-21.75-18.75-B-39-VU-00-00-0	21 3/4	18-3/4	217	0.29
QX-21.75-20.00-B-39-VU-00-00-0		20	233	
QX-21.75-42.75-B-39-VU-00-00-0		42-3/4	538	
QX-21.75-44.00-B-39-VU-00-00-0		44	554	
100 MM H14 (99.995% @ MPPS)				
HX-21.75-18.75-B-39-VU-00-00-0	21 3/4	18-3/4	217	0.36
HX-21.75-20.00-B-39-VU-00-00-0		20	233	
HX-21.75-42.75-B-39-VU-00-00-0		42-3/4	538	
HX-21.75-44.00-B-39-VU-00-00-0		44	554	
100 MM ULPA (99.9995% @ MPPS)				
PX-21.75-18.75-B-39-VU-00-00-0	21 3/4	18-3/4	217	0.36
PX-21.75-20.00-B-39-VU-00-00-0		20	233	
PX-21.75-42.75-B-39-VU-00-00-0		42-3/4	538	
PX-21.75-44.00-B-39-VU-00-00-0		44	554	

Pharmaseal Module Model Number System

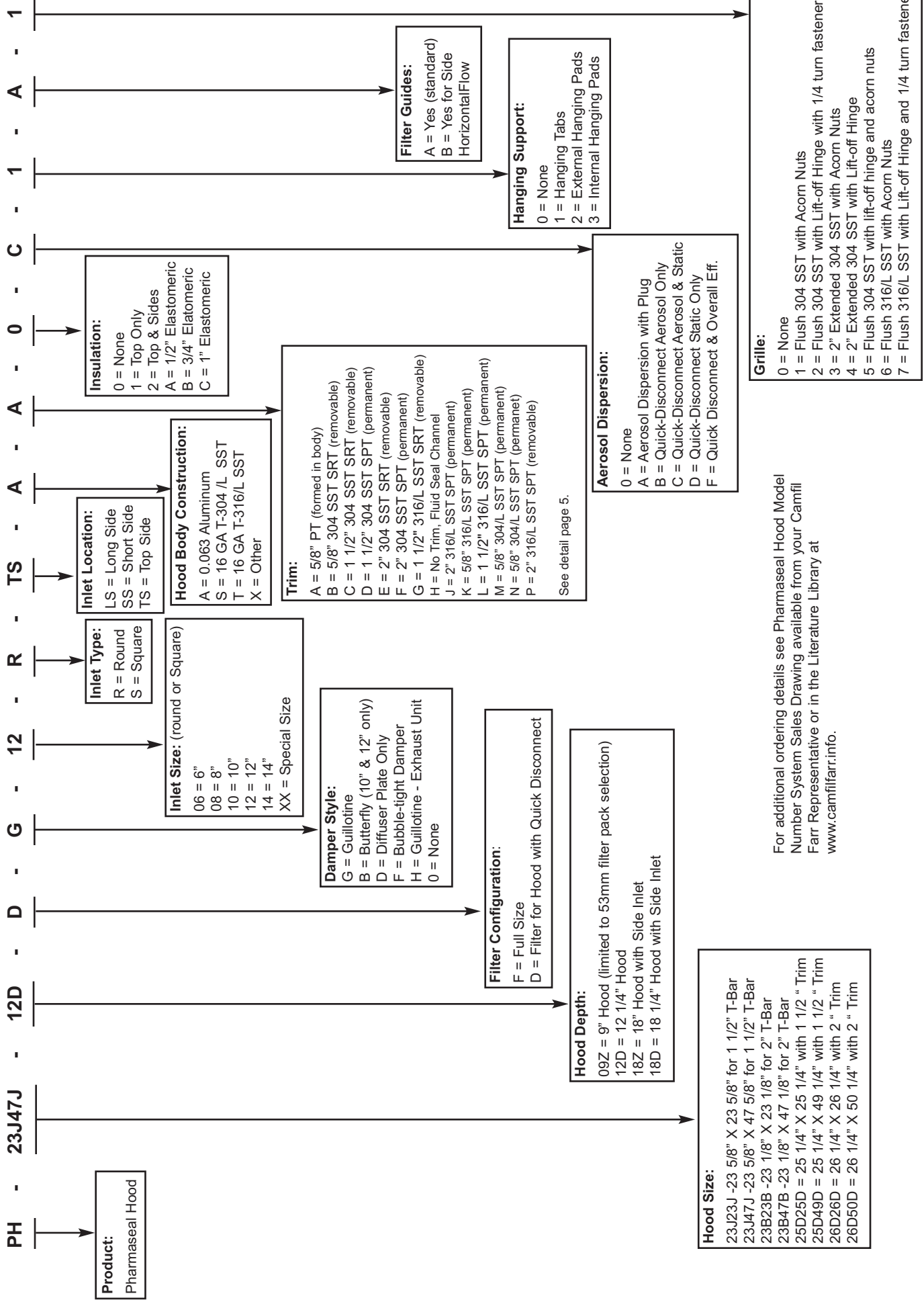

Pharmaseal Hood Selection Procedure

As diverse as the applications where it may be applied, the Pharmaseal offers various construction options to ensure that the assembled product addresses the intricacies of the application. This page is offered as a guideline to assembling a module.

PH -

PH - designates the Camfil Farr Pharmaseal product line

PH - **23J47J**

designates the overall hood size and the desired trim component.

PH - 23J47J - **12D**

designates the hood depth, with four selections available. For additional options, contact factory

PH - 23J47J - 12D - **D**

designates the filter configuration; either full size filter, or filter for hood with quick disconnects

PH - 23J47J - 12D - D - **G**

Designates the damper style, with selections of guillotine, butterfly, diffuser plate or none

PH - 23J47J - 12D - D - G - **12**

Designates the inlet size which may be round or square, in 6", 8", 10", 12", or 14" sizes

PH - 23J47J - 12D - D - G - 12 - **R**

Designates the inlet type, round or square

PH - 23J47J - 12D - D - G - 12 - R - **TS**

Designates the inlet location, either long side, short side or top side

PH - 23J47J - 12D - D - G - 12 - R - TS - **A**

Designates the hood construction of either aluminum, stainless steel, or other with factory consultation

PH - 23J47J - 12D - D - G - 12 - R - TS - A - **A**

Designates the required trim

PH - 23J47J - 12D - D - G - 12 - R - TS - A - A - **0**

Designates whether the unit requires insulation and where the insulation is to be applied

PH - 23J47J - 12D - D - G - 12 - R - TS - A - A - 0 - **C**

Designates the aerosol dispersion design for in-place filter evaluation

PH - 23J47J - 12D - D - G - 12 - R - TS - A - A - 0 - C - **1**

Designates the type of required supports; none, hanging tabs, or hanging pads

PH - 23J47J - 12D - D - G - 12 - R - TS - A - A - 0 - C - 1 - **A**

Designates filter guides which are standard on every Pharmaseal

PH - 23J47J - 12D - D - G - 12 - R - TS - A - A - 0 - C - 1 - A - **1**

Designates the grille type

The final model number would designate a Pharmaseal Hood, 23 5/8" by 47 5/8" for 1 1/2' trim, with a 12 1/4" hood depth, a filter for hood with quick-disconnect, a guillotine damper, a 12" inlet (round), located on the top side, constructed of aluminum, with 5/8" trim, no insulation, a quick-disconnect with aerosol and static ports, hanging tabs, filter guides and a flush stainless steel grille with acorn nuts.

Final step: Select appropriate filter on page 6 to match hood configuration.



Please contact your local Camfil Farr Representative or Camfil Farr for:

- Pharmaseal A & E Guide.
- Pharmaseal Installation & Operation Manual.
- Pharmaseal Specifications.

Camfil Farr
Washington NC
(252) 975-1141
literature@camfilfarr.com

www.camfilfarr.com or www.camfilfarr.info

Camfil Farr has a policy of uninterrupted research, development and product improvement. We reserve the right to change designs and specifications without notice.

Camfil Farr, Inc.

United States Tel: (973) 616-7300 Fax: (973) 616-7771
Canada Tel: (450) 629-3030 Fax: (450) 662-6035
E-mail: camfilfarr@camfilfarr.com

© Camfil Farr

<http://www.camfilfarr.info>
<http://www.camfilfarr.com>

